

THIS DRAWING IS UNPUBLISHED. RELEASED FOR PUBLICATION, 19 .
 © COPYRIGHT 19 BY AMP INCORPORATED. ALL INTERNATIONAL RIGHTS RESERVED.

LOC	DIST	P	F	ZONE	LTR	DESCRIPTION	DATE	APPD
G	14					D REVISED PER 0720-0044-94	4/27/94	OKS DAP

METRIC
 DIMENSIONS LISTED IN mm [INCHES]

AMP WIRE RANGE	E13288 Listed
22-16 AWG SOLID OR STRANDED	NOT APPLICABLE
LR7189 Certified	MILITARY P/N AND CLASS
NOT APPLICABLE	NOT APPLICABLE

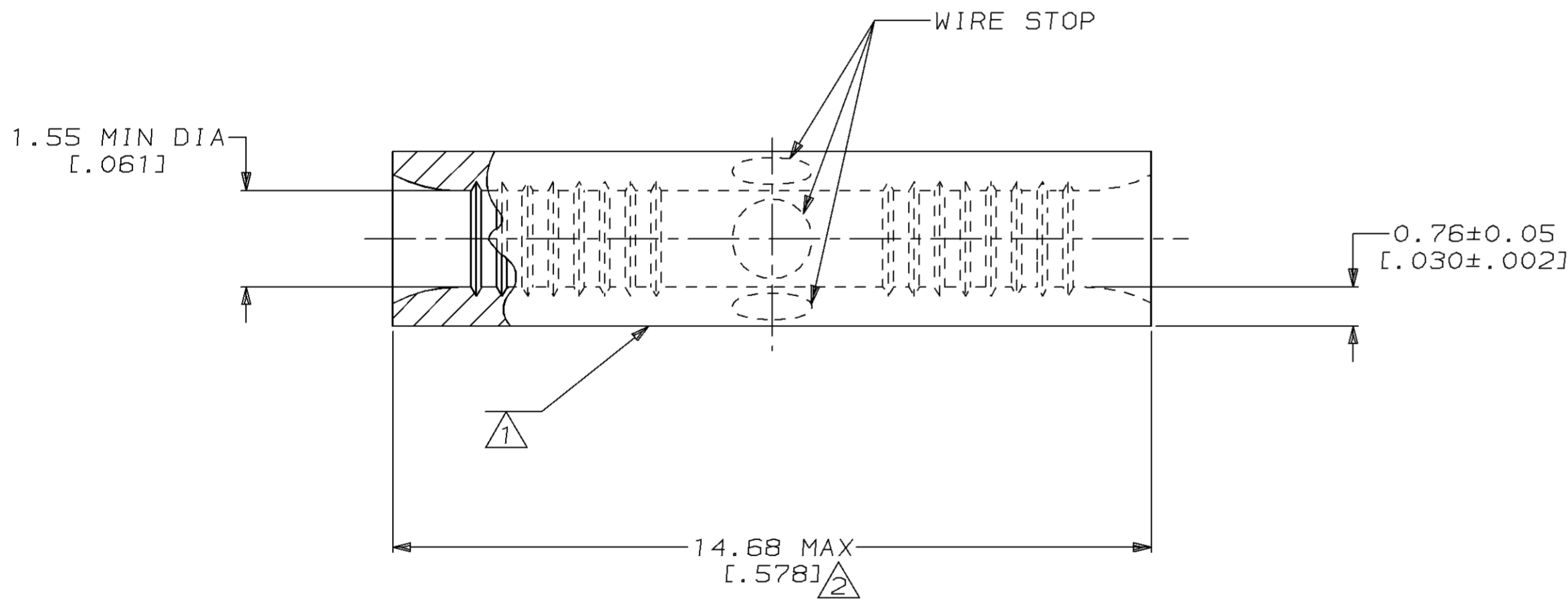
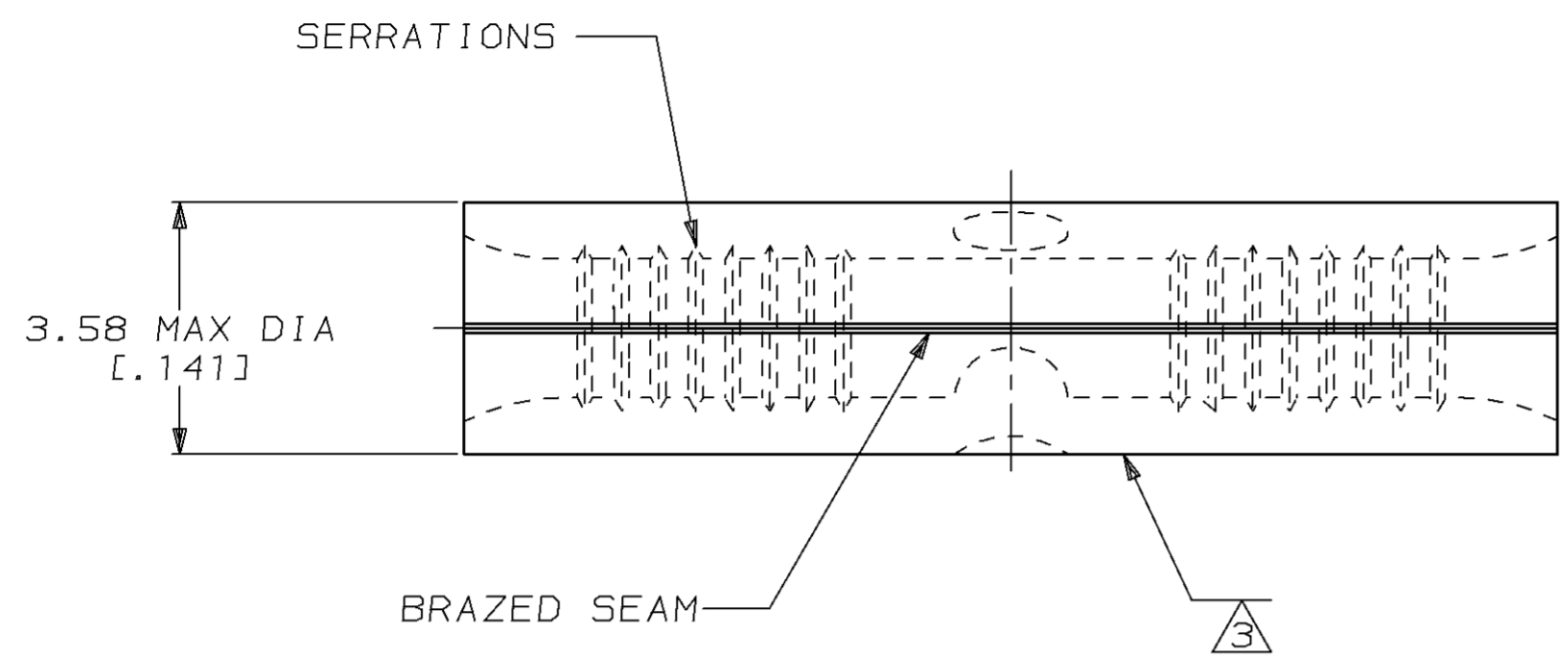

- 1 STAMP AMP 22-18 APPROX AS SHOWN
22-16 SPLICES ARE STAMPED 22-18 IN
ACCORDANCE WITH MILITARY SPEC MIL-T-7928
COMMERCIAL WIRE RANGE IS 22-16
- 2 MAXIMUM LENGTH DOES NOT INCLUDE
MANUFACTURING TABS
- 3 WIRE BARREL COLOR CODED ORANGE
TO DENOTE NICKEL MATERIAL

100	LOOSE PIECE, BOX SPECIAL (NO WINDOW)	8-322324-5
----	LOOSE PIECE	322324
QUANTITY	PACKAGE TYPE	PART NO

AMP INCORPORATED
CUSTOMER SERVICE SYSTEMS

FOR ADDITIONAL
 PRODUCT INFORMATION OR
 COPIES OF DRAWINGS
 AND TECHNICAL DOCUMENTS

PRODUCT INFORMATION CENTER
 1-800-522-6752

FOR APPLICATION
 TOOLING INFORMATION

TOOLING ASSISTANCE CENTER
 1-800-722-1111

FOR ORDER ENTRY

1-800-526-5142

MAX RECOMMENDED OPERATING
 TEMPERATURE:
 649°C MAX

VOLTAGE RATING:
 NOT APPLICABLE

WIRE CROSS SECTIONAL AREA RANGE:
 0.26-1.65mm² [509-3,260] CIR MILS
 SOLID OR STRANDED

THIS DRAWING IS A CONTROLLED DOCUMENT FOR
 AMP INCORPORATED. IT IS SUBJECT TO CHANGE
 AND THE CONTROLLING ENGINEERING ORGANIZATION
 SHOULD BE CONTACTED FOR THE LATEST REVISION.

DO NOT SCALE PRINT.
 UNLESS SPECIFIED
 DIMENSIONS IN mm [INCHES]
 TOLERANCES ON :

2 PLC DEC ± -
 3 PLC DEC ± -
 ANGLES ± -

MATERIAL
 NICKEL PER
 ASTM B-162
 ANNEALED

FINISH
 -

DR 4-19-93
 TA BRINKMAN

CHK 4-19-93
 DA PATTERSON

APPD 4-19-93
 DE MILLER

APPD 4-19-93
 JL MECKLEY

PRODUCT SPEC
 -

APPLICATION SPEC
 -

WEIGHT
 -

AMP AMP Incorporated
 Harrisburg, PA 17105-3608

NAME
**SPLICE, BUTT, STANDARD,
 HIGH TEMPERATURE,
 STRATO-THERM™**

SIZE
 C 00779

CAGE CODE
 G=322324

DRAWING NO
 G=322324

SCALE 10:1

SHEET 1 OF 1